

# Steel Disc Couplings

## RINGFEDER® TND XSX

Hubs with RINGFEDER® Shrink Discs, Single-Jointed, without Spacer, Shaft-Hub Connection by Shrink Disc

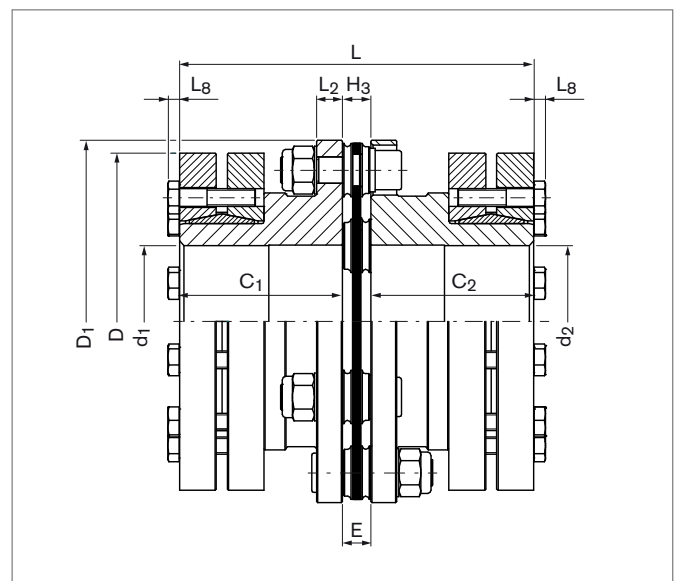

Size	T <sub>KNHD</sub> 1)	T <sub>KNHT</sub> 1)	n <sub>max</sub>	d <sub>1</sub> ;d <sub>2</sub> 3)	d <sub>1</sub> ;d <sub>2</sub> 3)	C <sub>1</sub> / C <sub>2</sub>	E	H <sub>3</sub>	D <sub>1</sub>	L <sub>2</sub>	L	n <sub>Sc</sub>	
<b>XSX</b>	Nm	Nm	1/min	mm	mm	mm	mm	mm	mm	mm	mm	mm	Quantity
82	750	1050	3600	38	60	55	10,5	10,5	116	10	120,5	6	
98	1350	1750	3600	50	70	60	12	12	140,5	11	132	6	
118	2400	3000	3600	50	75	75	13	13	166,5	12	163	6	
141	4000	5200	3400	65	95	90	15	15	198,5	14	195	6	
169	6500	8500	3000	65	105	125	21	21	238	16	271	6	
205	21000	26000	2500	95	145	160	28	28	295	22	348	8	
254	36000	44000	2100	95	160	200	32,5	32,5	345	26	432,5	8	

Size	G <sub>Wsp</sub>	C <sub>TdynHD</sub>	C <sub>TdynHT</sub>	Max. Permissible Misalignment 7)					
				axial		angular		radial	
	kg	10 <sup>6</sup> Nm/rad	10 <sup>6</sup> Nm/rad	ΔK <sub>aHD</sub>	ΔK <sub>aHT</sub>	ΔK <sub>wHD</sub>	ΔK <sub>wHT</sub>	ΔK <sub>rHD</sub>	ΔK <sub>rHT</sub>
XSX				mm	mm	Degrees	Degrees	mm	mm
82	0,5	0,637	0,743	0,7	0,4	1	0,7	---	---
98	0,85	1,173	1,251	1	0,6	1	0,7	---	---
118	1,36	2	2,082	1,2	0,8	1	0,7	---	---
141	2,096	2,992	3,142	1,4	0,8	1	0,7	---	---
169	4,032	5,269	6,586	1,5	1,2	1	0,7	---	---
205	10,903	21,848	22,285	1,1	0,6	0,5	0,4	---	---
254	18,135	37,204	37,868	1,1	0,8	0,5	0,4	---	---

1) When selecting the coupling size, it is essential to observe the instructions on coupling dimensioning in the document "Product Paper & Tech Paper RINGFEDER® Steel Disc Couplings". Short-term peak torque T<sub>kmax</sub> is limited to 1.75 multiples of T<sub>KN</sub> or by the transmissible torque T of the shrink disc.

7) The maximum misalignment values must not apply simultaneously. The instructions on coupling dimensioning in the document "Product Paper & Tech Paper RINGFEDER® Steel Disc Couplings" are to be observed.

3) Bore tolerance H6 up to diameter 80 mm; Bore tolerance H7 from diameter 80 mm.

To continue see next page

## Steel Disc Couplings RINGFEDER® TND XSX

### Shaft-Hub Connection by Shrink Discs RINGFEDER® RfN 4061

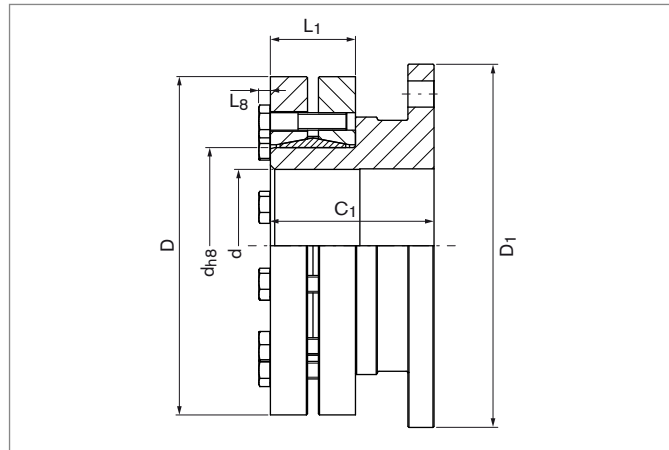

Shrink Discs RINGFEDER® RfN 4061						Sizing RINGFEDER® TND XSX							
dh8	x	D	L1	L8	d	T	Size	D1	C1 / C2	T <sub>KNHD</sub> 1)	T <sub>KNHT</sub> 1)	n <sub>max</sub>	GW <sub>HS</sub>
mm		mm	mm	mm	mm	Nm	XSX	mm	mm	Nm	Nm	1/min	kg
50	x	90	27,5	4	38	1350	82	116	55	750	1050	3600	2,3
					40	1500							
					42	1700							
55	x	100	30,5	4	42	1300	82	116	55	750	1050	3600	2,4
					45	1550							
					48	1800							
68	x	115	30,5	4	48	1700	82	116	55	750	1050	3600	2,8
					55	2250							
					60	2850							
75	x	138	32,5	5,3	55	2650	98	140,5	60	1350	1750	3600	4,4
					60	3300							
					65	4050							
80	x	145	32,5	5,3	60	3200	98	140,5	60	1350	1750	3600	4,6
					65	3900							
					70	4600							
90	x	155	39	5,5	65	4800	118	166,5	75	2400	3000	3600	7,2
					70	6050							
					75	7300							
115	x	185	56	6,4	75	9100	141	198,5	90	4000	5200	3400	12,6
					90	12100							
					95	14050							
140	x	230	60,5	7,5	95	15100	169	238	125	6500	8500	3000	24,4
					100	17550							
					105	20000							
165	x	290	71	10	105	25000	205	295	160	21000	26000	2500	48,8
					120	35500							
					125	39400							
185	x	330	86,4	10	125	43500	205	295	160	21000	26000	2500	60,4
					140	57350							
					145	62400							
200	x	350	86	10	145	69000	254	345	200	36000	44000	2100	77,7
					155	81000							
					160	87200							

The transmissible torque of the coupling is dependent on the selected disc pack as well as the type of the shaft-hub connection. The lower torque limits the transmissibility and must be taken as a basis for the selection of the coupling.

To continue see next page

## Steel Disc Couplings RINGFEDER® TND XSX

### Explanations

<b>T<sub>KNHD</sub></b> = Nom. transmissible torque with disc pack HD	<b>L<sub>2</sub></b> = Hub flange thickness	<b>ΔK<sub>wHT</sub></b> = Max. permissible angular misalignment with disc pack HT
<b>T<sub>KNHT</sub></b> = Nom. transmissible torque with disc pack HT	<b>L</b> = Total length	<b>ΔK<sub>r,HD</sub></b> = Max. permissible radial misalignment with disc pack HD
<b>n<sub>max</sub></b> = Max. rotational speed	<b>n<sub>Sc</sub></b> = Quantity of screws	<b>ΔK<sub>r,HT</sub></b> = Max. permissible radial misalignment with disc pack HT
<b>d<sub>1min</sub></b> = Min. bore diameter d <sub>1</sub>	<b>GW<sub>sp</sub></b> = Weight of spacer	
<b>d<sub>2min</sub></b> = Min. bore diameter d <sub>2</sub>	<b>GW<sub>hs</sub></b> = Weight of hub including shrink disc	
<b>d<sub>1max</sub></b> = Max. bore diameter d <sub>1</sub>	<b>C<sub>TdynHD</sub></b> = Dynamic torsional stiffness with disc pack HD	
<b>d<sub>2max</sub></b> = Max. bore diameter d <sub>2</sub>	<b>C<sub>TdynHT</sub></b> = Dynamic torsional stiffness with disc pack HT	
<b>C<sub>1</sub></b> = Guided length in hub bore	<b>ΔK<sub>a,HD</sub></b> = Max. permissible axial misalignment with disc pack HD	<b>Shrink Disc Selection</b>
<b>C<sub>2</sub></b> = Guided length in hub bore	<b>ΔK<sub>a,HT</sub></b> = Max. permissible axial misalignment with disc pack HT	<b>d<sub>h8</sub></b> = Inner diameter
<b>E</b> = Distance between hubs	<b>ΔK<sub>w,HD</sub></b> = Max. permissible angular misalignment with disc pack HD	<b>D</b> = Outer diameter
<b>H<sub>3</sub></b> = Width of the disc pack		<b>L<sub>1</sub></b> = Min. installation length (without screws)
<b>D<sub>1</sub></b> = Max. outer diameter		<b>L<sub>8</sub></b> = Overhang length
		<b>d</b> = Solid shaft diameter
		<b>T</b> = Transmissible torque

### Ordering example

Type	Size	Disc pack	Bore diameter d <sub>1</sub>	Shrink Disc RfN 4061 for bore diameter d <sub>1</sub>	Bore diameter d <sub>2</sub>	Shrink Disc RfN 4061 for bore diameter d <sub>2</sub>
TND XSX	98	HD	50	68 x 115	60	68 x 115

Further information on RINGFEDER® TND XSX on [www.ringfeder.com](http://www.ringfeder.com)

#### Technical Information

- The specified values for transmissible torques are valid as follows: Shaft tolerance h6 for shaft diameters up to 50 mm; Shaft tolerance g6 for shaft diameters from 50 mm; Surface quality R<sub>a</sub> ≤ 3.2 μm.
- From a peripheral speed of 30 m/s, separate balancing of the individual coupling parts is recommended.
- Without further instructions on balancing, the coupling parts are balanced individually according to DIN 21940-11 in quality G 6,3 at 1,500 1/min. The hubs are balanced without screwed-on disc pack.

#### Disclaimer of liability

All technical details and notes are non-binding and cannot be used as a basis for legal claims. The user is obligated to determine whether the represented products meet his requirements. We reserve the right to carry out modifications at any time in the interests of technical progress.