

Steel Disc Couplings

RINGFEDER® TND

Tables & Values

For the correct selection of a suitable coupling type and size, it is essential to observe the explanations in the chapter "Coupling Dimensioning".

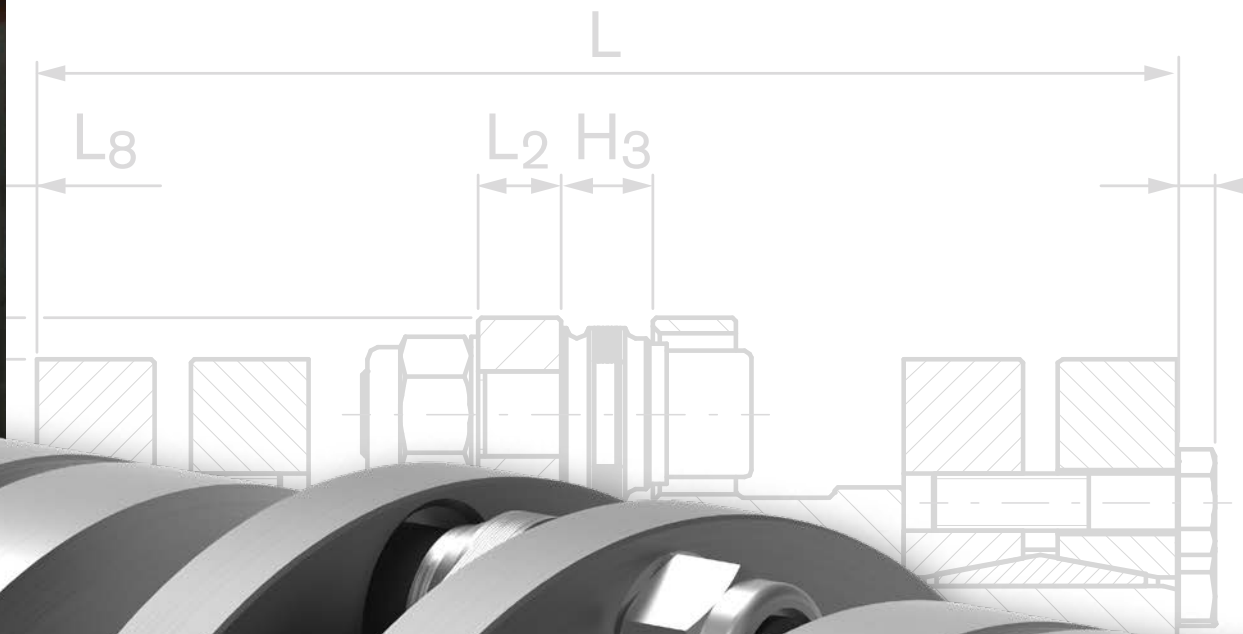

Steel Disc Couplings

RINGFEDER® TND HSH

Standard Hubs, Single-Jointed, without Spacer,
Shaft-Hub Connection by Keyway

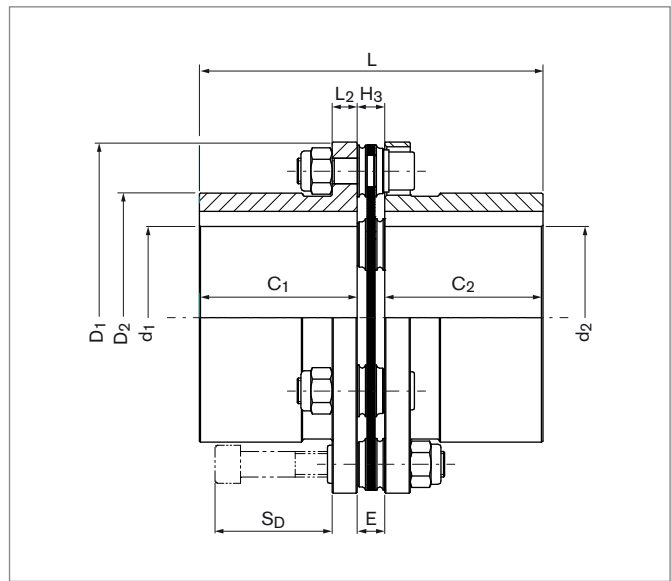
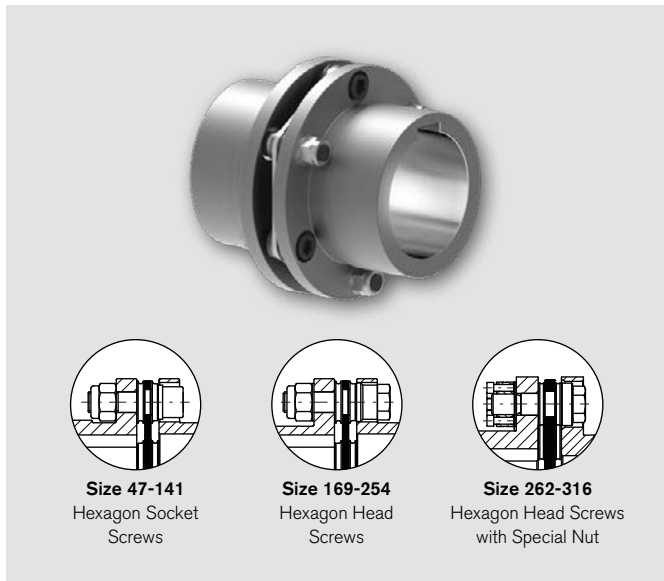

Size	T _{KNHD} ¹⁾	T _{KNHT} ¹⁾	n _{max}	d _{pre} ³⁾	d _{1k} ; d _{2k} max ⁴⁾	C ₁ / C ₂	E	H ₃	D ₁	D ₂	L ₂	L	S _D	n _{Sc}
HSH	Nm	Nm	1/min	mm	mm	mm	mm	mm	mm	mm	mm	mm	mm	Quantity
47	170	230	12200	10	32	39,5	7,5	7,5	70,5	47	5	86,5	24	6
63	320	420	9900	14	42	45	9	9	88	62,5	8	99	32	6
82	750	1050	7500	15	55	55	10,5	10,5	116	82	10	120,5	40	6
98	1350	1750	6200	19	65	60	12	12	140,5	98	11	132	47	6
118	2400	3000	5250	25	85	75	13	13	166,5	118	12	163	55	6
141	4000	5200	4400	30	95	90	15	15	198,5	141	14	195	64	6
169	6500	8500	3650	39	115	125	21	21	238	169	16	271	81	6
205	21000	26000	2950	59	140	160	28	28	295	205	22	348	112	8
254	36000	44000	2500	79	175	200	32,5	32,5	345	254	26	432,5	133	8
262	74000	---	2050	90	180	210	34	34	420	262	32	454	137	8
316	130000	---	1700	100	215	240	47	47	510	316	38	527	172	8

To continue see next page

Steel Disc Couplings RINGFEDER® TND HSH

Size	G _{WSB} ⁶⁾	J _{SB} ⁶⁾	C _{TdynHD}	C _{TdynHT}	Max. Permissible Misalignment ⁷⁾					
					axial		angular		radial	
HSH	kg	10 ⁻³ kgm ²	10 ⁶ Nm/rad	10 ⁶ Nm/rad	ΔK _a HD	ΔK _a HT	ΔK _w HD	ΔK _w HT	ΔK _r HD	ΔK _r HT
					mm	mm	Degrees	Degrees	mm	mm
47	1,3	0,5	0,173	0,184	0,5	0,3	1	0,7	---	---
63	2,6	1,6	0,281	0,312	0,5	0,4	1	0,7	---	---
82	5,6	5,9	0,637	0,743	0,7	0,4	1	0,7	---	---
98	8,8	14	1,173	1,251	1	0,6	1	0,7	---	---
118	15,4	35	2	2,082	1,2	0,8	1	0,7	---	---
141	25,9	84	2,992	3,142	1,4	0,8	1	0,7	---	---
169	50	230	5,269	6,586	1,5	1,2	1	0,7	---	---
205	97,8	700	21,848	22,285	1,1	0,6	0,5	0,4	---	---
254	171,2	1750	37,204	37,868	1,1	0,8	0,5	0,4	---	---
262	223,2	3260	46,192	---	1,6	---	0,5	---	---	---
316	384,4	8650	87,706	---	1,8	---	0,5	---	---	---

1) When selecting the size, it is essential to observe the instructions on coupling dimensioning in the document "Product Paper & Tech Paper RINGFEDER® Steel Disc Couplings". Short-term peak torque T_{Kmax} is limited to 1.75 multiples of T_{KN}.

3) Pre-bore has free tolerance.

4) Maximum finished bore with keyways according to DIN 6885-1.

6) Weight and mass moments of inertia for pre-bored hubs.

7) The maximum misalignment values must not apply simultaneously. The instructions on coupling dimensioning in the document "Product Paper & Tech Paper RINGFEDER® Steel Disc Couplings" are to be observed.

Explanations

T_{KNHD} = Nom. transmissible torque with disc pack HD	D₁ = Max. outer diameter	ΔK_aHD = Max. permissible axial misalignment with disc pack HD
T_{KNHT} = Nom. transmissible torque with disc pack HT	D₂ = Outer diameter hub	ΔK_aHT = Max. permissible axial misalignment with disc pack HT
n_{max} = Max. rotational speed	L₂ = Hub flange thickness	ΔK_wHD = Max. permissible angular misalignment with disc pack HD
d_{pre} = Diameter pre-bore	L = Total length	ΔK_wHT = Max. permissible angular misalignment with disc pack HT
d_{1kmax} = Max. bore diameter d ₁ with keyway acc. to DIN 6885-1	S_D = Disassembly space	ΔK_rHD = Max. permissible radial misalignment with disc pack HD
d_{2kmax} = Max. bore diameter d ₂ with keyway acc. to DIN 6885-1	n_{sc} = Quantity of screws	ΔK_rHT = Max. permissible radial misalignment with disc pack HT
C₁ = Guided length in hub bore	G_{WSB} = Weight at smallest bore diameter	
C₂ = Guided length in hub bore	J_{SB} = Moment of inertia at smallest bore diameter.	
E = Distance between hubs	C_{TdynHD} = Dynamic torsional stiffness with disc pack HD	
H₃ = Width of the disc pack	C_{TdynHT} = Dynamic torsional stiffness with disc pack HT	

Ordering example

Type	Size	Disc pack	Bore diameter d ₁	Bore diameter d ₂
TND HSH	118	HD	60	80

Technical Information

- Without further specifications, we deliver as standard: Bore tolerance H7; Keyway acc. to DIN 6885-1; Keyway width tolerance P9; Set screw per hub.
- From a peripheral speed of 30 m/s, separate balancing of the individual coupling parts is recommended.
- Without further instructions on balancing, the coupling parts are balanced individually according to DIN 21940-11 in quality G 6,3 at 1,500 1/min. The hubs are balanced half key (before grooving).

Further information on RINGFEDER® TND HSH on www.ringfeder.com

Disclaimer of liability

All technical details and notes are non-binding and cannot be used as a basis for legal claims. The user is obligated to determine whether the represented products meet his requirements. We reserve the right to carry out modifications at any time in the interests of technical progress.