

Steel Disc Couplings

RINGFEDER® TND HDV

Combination of Standard Hub and Inverted Hub, Double-Jointed, with Spacer, Shaft-Hub Connection by Keyway

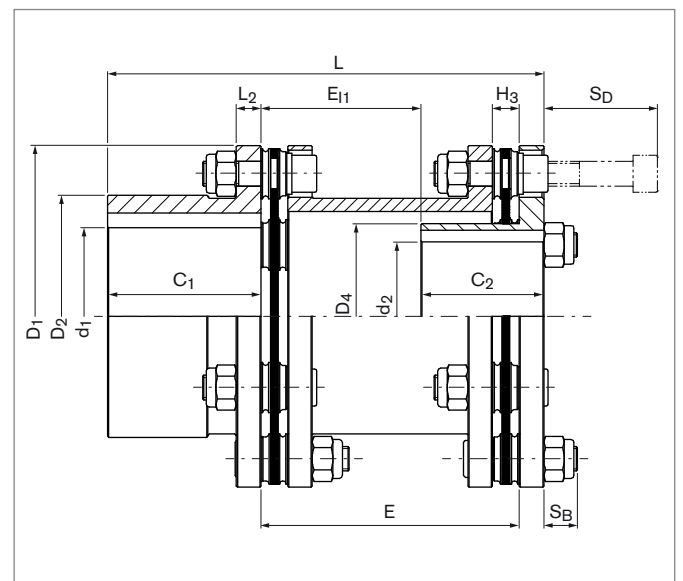
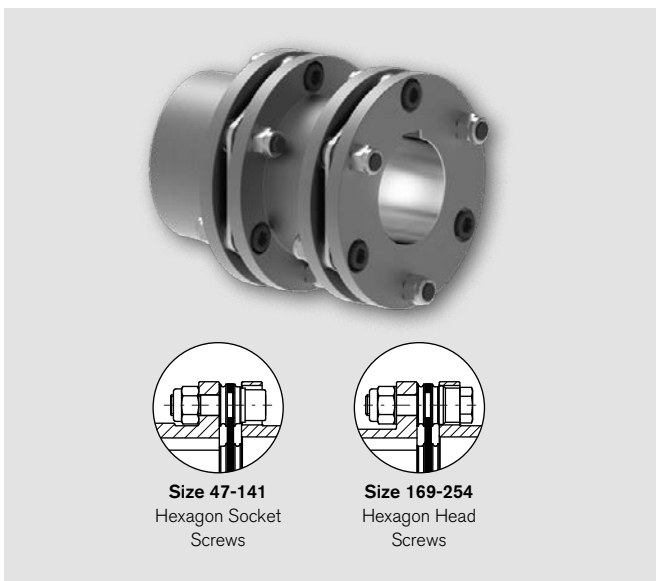

Size	T _{KNHD} ¹⁾	T _{KNHT} ¹⁾	n _{max} ²⁾	d _{pre} ³⁾	d _{1kmax} ⁴⁾	d _{2kmax} ⁴⁾	C ₁ /C ₂	E ₁	E ⁵⁾	H ₃	D ₁	D ₂	D ₄	L ₂	L	S _B	S _D	n _{Sc}
HDV	Nm	Nm	1/min	mm	mm	mm	mm	mm	mm	mm	mm	mm	mm	mm	mm	mm	mm	Quantity
47	170	230	12200	10	32	25	39,5	25,5	60	7,5	70,5	47	37	5	105	7	24	6
								65,5	100						145			
								105,5	140						185			
63	320	420	9900	14	42	32	45	33	70	9	88	62,5	48	8	123	9	32	6
								43	80						133			
								63	100						153			
								103	140						193			
82	750	1050	7500	15	55	44	55	55	100	10,5	116	82	64	10	165	11	40	6
								95	140						205			
								135	180						245			
98	1350	1750	6200	19	65	50	60	51	100	12	140,5	98	77	11	171	15	47	6
								91	140						211			
								131	180						251			
118	2400	3000	5250	25	85	60	75	37	100	13	166,5	118	90,5	12	187	17	55	6
								77	140						227			
								117	180						267			
141	4000	5200	4400	30	95	75	90	64	140	15	198,5	141	114	14	244	18	64	6
								104	180						284			
								31	140						281			
169	6500	8500	3650	39	115	90	125	71	180	21	238	169	135	16	321	24	81	6
								141	250						391			

To continue see next page

Steel Disc Couplings RINGFEDER® TND HDV

Size	T _{KNHD} ¹⁾	T _{KNHT} ¹⁾	n _{max} ²⁾	d _{pre} ³⁾	d _{1kmax} ⁴⁾	d _{2kmax} ⁴⁾	C _{1/C2}	E _{I1}	E ⁵⁾	H ₃	D ₁	D ₂	D ₄	L ₂	L	S _B	S _D	n _{Sc}
HDV	Nm	Nm	1/min	mm	mm	mm	mm	mm	mm	mm	mm	mm	mm	mm	mm	mm	mm	Quantity
205	21000	26000	2950	59	140	115	160	62 112	200 250	28	295	205	170	22	382 432	27	112	8
254	36000	44000	2500	79	175	120	200	50 76 126	224 250 300	32,5	345	254	180	26	450 476 526	29	133	8

Size	E ⁵⁾	G _{WSB} ⁶⁾	J _{SB} ⁶⁾	C _{TdynHD}	C _{TdynHT}	Max. Permissible Misalignment ⁷⁾					
						axial		angular		radial	
HDV	mm	kg	10 ⁻³ kgm ²	10 ⁶ Nm/rad	10 ⁶ Nm/rad	ΔK _s HD	ΔK _s HT	ΔK _w HD	ΔK _w HT	ΔK _r HD	ΔK _r HT
						mm	mm	Degrees	Degrees	mm	mm
47	60	1,4	0,69	0,071	0,075					0,8	0,6
	100	1,6	0,75	0,059	0,062	1,0	0,6	2	1,4	1,5	1,1
	140	1,7	0,8	0,051	0,053					2,2	1,5
63	70	2,9	2,33	0,123	0,134					1	0,7
	80	2,9	2,37	0,123	0,134					1,1	0,8
	100	3	2,46	0,116	0,127	1,0	0,8	2	1,4	1,5	1,1
	140	3,2	2,63	0,105	0,114					2,1	1,6
82	100	5,4	8,83	0,271	0,308					1,4	1,1
	140	6,7	9,23	0,246	0,277	1,4	0,8	2	1,4	2,1	1,5
	180	7	9,65	0,226	0,251					2,8	2,1
98	100	9,9	20,35	0,513	0,543					1,5	1
	140	10,4	21,21	0,469	0,494	2,0	1,2	2	1,4	2,1	1,5
	180	10,8	22,07	0,433	0,454					2,8	2
118	100	16	46,28	0,914	0,948					1,4	1
	140	16,7	48,34	0,855	0,884	2,4	1,6	2	1,4	2,1	1,5
	180	17,3	50,39	0,803	0,829					2,8	2
141	140	26,4	98,01	1,306	1,362	2,8	1,6	2	1,4	2	1,5
	180	28,5	105,33	1,229	1,279					2,7	2
169	140	50,7	289,79	2,467	3,035					2	1,4
	180	52,3	299,74	2,375	2,898	3	2,4	2	1,4	2,6	1,9
	250	55	317,15	2,231	2,686					3,8	2,7
205	200	105	951,03	8,995	9,142	2,2	1,2	1	0,8	1,4	1,2
	250	107,8	975,71	8,265	8,389					1,8	1,5
254	224	169,2	2131,73	14,975	15,19	2,2	1,6	1	0,8	1,6	1,3
	250	171,2	2152,56	14,302	14,497					1,8	1,5
	300	175	2192,61	13,163	13,328					2,2	1,8

- When selecting the size, it is essential to observe the instructions on coupling dimensioning in the document "Product Paper & Tech Paper RINGFEDER® Steel Disc Couplings". Short-term peak torque T_{kmax} is limited to 1.75 multiples of T_{KN}.
- For longer spacers, check bending critical rotational speed.
- Pre-bore has free tolerance.
- Maximum finished bore with keyways according to DIN 6885-1.

- Longer spacers on request.
- Weight and mass moments of inertia for pre-bored hubs.
- The maximum misalignment values must not apply simultaneously. The instructions on coupling dimensioning in the document "Product Paper & Tech Paper RINGFEDER® Steel Disc Couplings" are to be observed.

To continue see next page

Steel Disc Couplings RINGFEDER® TND HDV

Explanations

T_{KNHD} = Nom. transmissible torque with disc pack HD	H₃ = Width of the disc pack	C_{TdynHD} = Dynamic torsional stiffness with disc pack HD
T_{KNHT} = Nom. transmissible torque with disc pack HT	D₁ = Max. outer diameter	C_{TdynHT} = Dynamic torsional stiffness with disc pack HT
n_{max} = Max. rotational speed	D₂ = Outer diameter hub	ΔK_{aHD} = Max. permissible axial misalignment with disc pack HD
d_{pre} = Diameter pre-bore	D₄ = Outer diameter of the inverted hub	ΔK_{aHT} = Max. permissible axial misalignment with disc pack HT
d_{1kmax} = Max. bore diameter d ₁ with keyway acc. to DIN 6885-1	L₂ = Hub flange thickness	ΔK_{wHD} = Max. permissible angular misalignment with disc pack HD
d_{2kmax} = Max. bore diameter d ₂ with keyway acc. to DIN 6885-1	L = Total length	ΔK_{wHT} = Max. permissible angular misalignment with disc pack HT
C₁ = Guided length in hub bore	S_B = Protruding of the screw	ΔK_{rHD} = Max. permissible radial misalignment with disc pack HD
C₂ = Guided length in hub bore	S_D = Disassembly space	ΔK_{rHT} = Max. permissible radial misalignment with disc pack HT
E₁₁ = Distance between hubs	n_{sc} = Quantity of screws	
E = Distance between hubs	G_{WSB} = Weight at smallest bore diameter	
	J_{SB} = Moment of inertia at smallest bore diameter	

Ordering example

Type	Size	Disc pack	Distance between hubs E	Bore diameter d ₁	Bore diameter d ₂
TND HDV	118	HD	140	85	60

Further information on
RINGFEDER® TND HDV
 on www.ringfeder.com

Technical Information

- Without further specifications, we deliver as standard: Bore tolerance H7; Keyway acc. to DIN 6885-1; Keyway width tolerance P9; Set screw per hub.
- From a peripheral speed of 30 m/s, separate balancing of the individual coupling parts is recommended.
- Without further instructions on balancing, the coupling parts are balanced individually according to DIN 21940-11 in quality G 6,3 at 1,500 1/min. The hubs are balanced half key (before grooving), the spacer without screwed-on disc packs.

Disclaimer of liability

All technical details and notes are non-binding and cannot be used as a basis for legal claims. The user is obligated to determine whether the represented products meet his requirements. We reserve the right to carry out modifications at any time in the interests of technical progress.