

Steel Disc Couplings

RINGFEDER® TND HDH

Standard Hubs, Double-Jointed, with Spacer,
Shaft-Hub Connection by Keyway

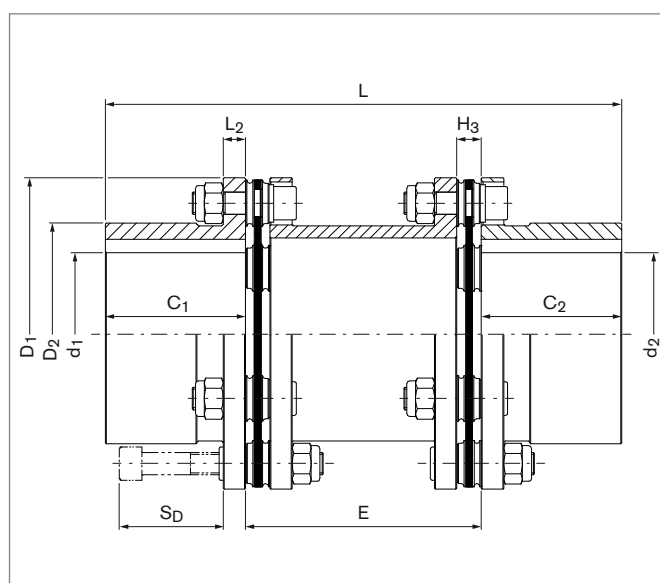
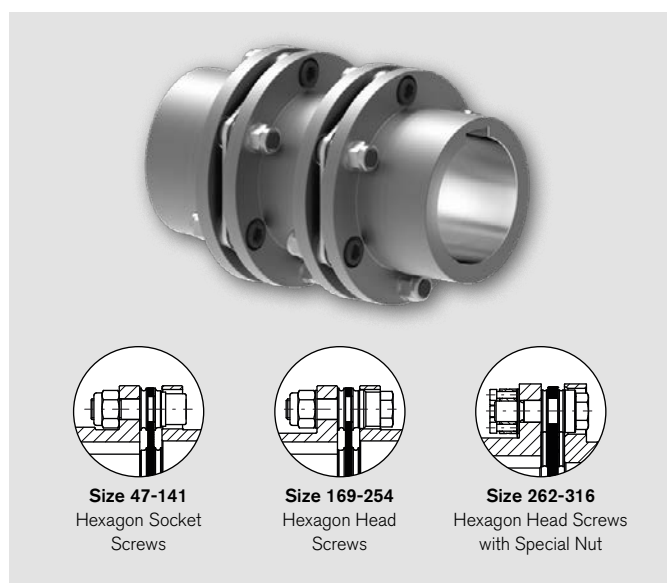

Size	T _{KNHD} ¹⁾	T _{KNHT} ¹⁾	n _{max} ²⁾	d _{pre} ³⁾	d _{1k;d_{2k}} ⁴⁾	C ₁ / C ₂	E ⁵⁾	H ₃	D ₁	D ₂	L ₂	L	S _D	n _{Sc}
HDH	Nm	Nm	1/min	mm	mm	mm	mm	mm	mm	mm	mm	mm	mm	Quantity
47	170	230	12200	10	32	39,5	60	7,5	70,5	47	5	139	24	6
							100					179		
							140					219		
63	320	420	9900	14	42	45	70	9	88	62,5	8	160	32	6
							80					170		
							100					190		
							140					230		
82	750	1050	7500	15	55	55	100	10,5	116	82	10	210	40	6
							140					250		
							180					290		
98	1350	1750	6200	19	65	60	100	12	140,5	98	11	220	47	6
							140					260		
							180					300		
118	2400	3000	5250	25	85	75	100	13	166,5	118	12	250	55	6
							140					290		
							180					330		
141	4000	5200	4400	30	95	90	140	15	198,5	141	14	320	64	6
							180					360		
							140					390		
169	6500	8500	3650	39	115	125	180	21	238	169	16	430	81	6
							180					430		
							250					500		

To continue see next page

Steel Disc Couplings RINGFEDER® TND HDH

Size	T _{KNHD} ¹⁾	T _{KNHT} ¹⁾	n _{max} ²⁾	d _{pre} ³⁾	d _{1k;d2k} max ⁴⁾	C ₁ / C ₂	E ⁵⁾	H ₃	D ₁	D ₂	L ₂	L	S _D	n _{sc}
HDH	Nm	Nm	1/min	mm	mm	mm	mm	mm	mm	mm	mm	mm	mm	Quantity
205	21000	26000	2950	59	140	160	200 250	28	295	205	22	520 570	112	8
254	36000	44000	2500	79	175	200	224 250 300	32,2	345	254	26	624 650 700	133	8
262	74000	---	2050	90	180	210	280	34	420	262	32	700	137	8
316	130000	---	1700	100	215	240	350	47	510	316	38	830	172	8

Size	E ⁵⁾	G _{WSB} ⁶⁾	J _{SB} ⁶⁾	C _{TdynHD}	C _{TdynHT}	Max. Permissible Misalignment ⁷⁾					
						axial ΔK _a HD	axial ΔK _a HT	angular ΔK _w HD	angular ΔK _w HT	radial ΔK _r HD	radial ΔK _r HT
HDH	mm	kg	10 ⁻⁹ kgm ²	10 ⁶ Nm/rad	10 ⁶ Nm/rad	mm	mm	Degrees	Degrees	mm	mm
47	60	1,7	0,76	0,071	0,075	1,0	0,6	2	1,4	0,8	0,6
	100	1,8	0,76	0,059	0,062						
	140	1,9	0,76	0,071	0,075						
	Δ per 100 mm	0,31	0,14	0,14							
63	70	3,3	2,5	0,126	0,139	1,0	0,8	2	1,4	1	0,7
	80	3,3	2,6	0,123	0,134						
	100	3,5	2,7	0,116	0,127						
	140	3,7	2,8	0,105	0,114						
Δ per 100 mm	0,55	0,44	0,44								
82	100	7,1	9,1	0,271	0,308	1,4	0,8	2	1,4	1,4	1,1
	140	7,4	9,5	0,246	0,277						
	180	7,7	9,9	0,226	0,251						
	Δ per 100 mm	0,74	0,10	1,06							
98	100	11,1	21	0,513	0,543	2,0	1,2	2	1,4	1,5	1
	140	11,5	22	0,469	0,494						
	180	12	23	0,433	0,454						
	Δ per 100 mm	1,09	1,04	2,18							
118	100	18,9	52	0,914	0,948	2,4	1,6	2	1,4	1,4	1
	140	19,6	54	0,855	0,884						
	180	20,3	56	0,803	0,829						
	Δ per 100 mm	1,74	5,14	5,24							
141	140	31,7	120	1,306	1,362	2,8	1,6	2	1,4	2	1,5
	180	32,5	130	1,229	1,279						
	Δ per 100 mm	1,92	8,14	8,3							
	140	60,2	340	2,467	3,035						
169	180	61,8	350	2,375	2,898	3	2,4	2	1,4	2,6	1,9
	250	64,5	360	2,231	2,686						
	Δ per 100 mm	3,92	24,88	25,36							
	200	119,6	1070	8,995	9,142						
205	250	122,4	1100	8,265	8,389	2,2	1,2	1	0,8	1,4	1,2
	Δ per 100 mm	5,56	49,36	50,3							

To continue see next page

Steel Disc Couplings RINGFEDER® TND HDH

Size	E ⁵⁾	G _{WSB} ⁶⁾	J _{SB} ⁶⁾	C _{TdynHD}	C _{TdynHT}	Max. Permissible Misalignment ⁷⁾					
						axial		angular		radial	
HDH	mm	kg	10 ⁻³ kgm ²	10 ⁶ Nm/rad	10 ⁶ Nm/rad	ΔK _a HD	ΔK _a HT	ΔK _w HD	ΔK _w HT	ΔK _r HD	ΔK _r HT
254	224	207,5	2620	14,975	15,19	2,2	1,6	1	0,8	1,6	1,3
	250	209,5	2640	14,302	14,497						
	300	213,3	2680	13,163	13,328						
	Δ per 100 mm	7,58	80,10	81,63							
262	280	261,9	5350	18,116	---	3,2	---	1	---	2,5	---
	Δ per 100 mm	8,75	121,28	122,81							
316	350	450,1	14430	36,134	---	3,8	---	1	---	3	---
	Δ per 100 mm	11,05	221,59	224,4							

- When selecting the size, it is essential to observe the instructions on coupling dimensioning in the document "Product Paper & Tech Paper RINGFEDER® Steel Disc Couplings". Short-term peak torque T_{kmax} is limited to 1.75 multiples of T_{KN}.
- For longer spacers, check bending critical rotational speed.
- Pre-bore has free tolerance.
- Maximum finished bore with keyways according to DIN 6885-1.
- Longer spacers on request. The figures given at "Δ per 100 mm" for G_{WSB}, J_{SB}, C_{TdynHD} and C_{TdynHT} are approximate values.
- Weight and mass moments of inertia for pre-bored hubs.
- The maximum misalignment values must not apply simultaneously. The instructions on coupling dimensioning in the document "Product Paper & Tech Paper RINGFEDER® Steel Disc Couplings" are to be observed.

Explanations

T_{KNHD} = Nom. transmissible torque with disc pack HD	D₁ = Max. outer diameter	ΔK_aHD = Max. permissible axial misalignment with disc pack HD
T_{KNHT} = Nom. transmissible torque with disc pack HT	D₂ = Outer diameter hub	ΔK_aHT = Max. permissible axial misalignment with disc pack HT
n_{max} = Max. rotational speed	L₂ = Hub flange thickness	ΔK_wHD = Max. permissible angular misalignment with disc pack HD
d_{pre} = Diameter pre-bore	L = Total length	ΔK_wHT = Max. permissible angular misalignment with disc pack HT
d_{1kmax} = Max. bore diameter d ₁ with keyway acc. to DIN 6885-1	S_D = Disassembly space	ΔK_rHD = Max. permissible radial misalignment with disc pack HD
d_{2kmax} = Max. bore diameter d ₂ with keyway acc. to DIN 6885-1	n_{sc} = Quantity of screws	ΔK_rHT = Max. permissible radial misalignment with disc pack HT
C₁ = Guided length in hub bore	G_{WSB} = Weight at smallest bore diameter	
C₂ = Guided length in hub bore	J_{SB} = Moment of inertia at smallest bore diameter.	
E = Distance between hubs	C_{TdynHD} = Dynamic torsional stiffness with disc pack HD	
H₃ = Width of the disc pack	C_{TdynHT} = Dynamic torsional stiffness with disc pack HT	

Ordering example

Type	Size	Disc pack	Distance between hubs E	Bore diameter d ₁	Bore diameter d ₂
TND HDH	118	HT	140	60	80

Technical Information

- Without further specifications, we deliver as standard: Bore tolerance H7; Keyway acc. to DIN 6885-1; Keyway width tolerance P9; Set screw per hub.
- From a peripheral speed of 30 m/s, separate balancing of the individual coupling parts is recommended.
- Without further instructions on balancing, the coupling parts are balanced individually according to DIN 21940-11 in quality G 6,3 at 1,500 1/min. The hubs are balanced half key (before grooving), the spacer without screwed-on disc packs.

Further information on RINGFEDER® TND HDH on www.ringfeder.com

Disclaimer of liability

All technical details and notes are non-binding and cannot be used as a basis for legal claims. The user is obligated to determine whether the represented products meet his requirements. We reserve the right to carry out modifications at any time in the interests of technical progress.